

# 4558

## DUAL OPERATIONAL AMPLIFIER

### DESCRIPTION

The 4558 is a monolithic integrated circuit designed for dual operational amplifier.

### FEATURES

- \*No frequency compensation required.
- \*No latch-up
- \*Large common mode and differential voltage range
- \*Parameter tracking over temperature range
- \*Gain and phase match between amplifiers
- \*Internally frequency compensated
- \*Low noise input transistors

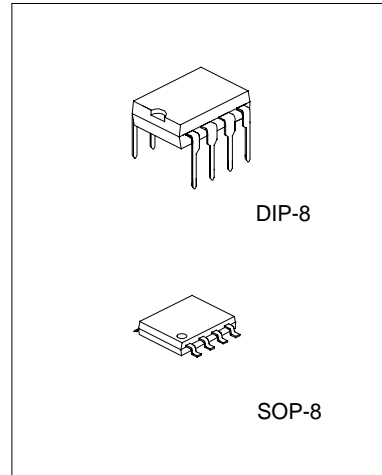

### BLOCK DIAGRAM

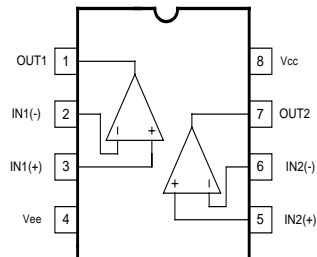
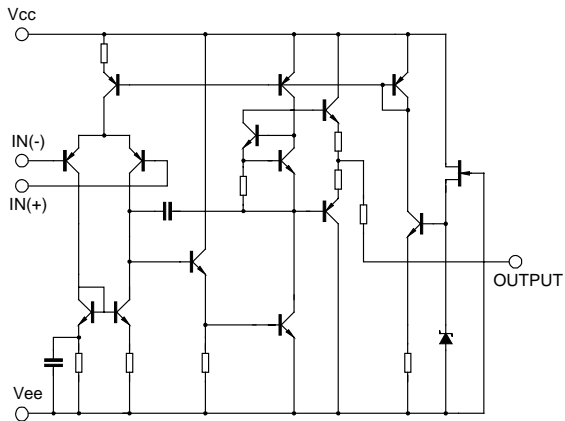

### ABSOLUTE MAXIMUM RATINGS

Characteristic	Symbol	Value	Unit
Supply Voltage	V <sub>CC</sub>	± 16	V
Differential input voltage	V <sub>I(DIFF)</sub>	±16	V
Power Dissipation	P <sub>D</sub>	400	mW
Input Voltage	V <sub>I</sub>	±15	V
Operating Temperature	T <sub>OPR</sub>	0~+70	°C
Storage Temperature	T <sub>STG</sub>	-65~+150	°C

**ELECTRICAL CHARACTERISTICS**( Ta=25°C ,Vcc=15V,Vee=-15V)

Characteristic	Symbol	Test Condition	Min	Typ.	Max	Unit
Supply Current	I <sub>cc</sub>			3.5	5.6	mA
Input offset voltage	V <sub>IO</sub>	R <sub>s</sub> <10kΩ		2	6	mV
Input offset current	I <sub>IO</sub>			5	200	nA
Input bias current	I <sub>BIAS</sub>			30	500	nA
Large signal voltage gain	G <sub>v</sub>	V <sub>o</sub> (p-p)=10V,R <sub>L</sub> <2kΩ	20	200		V/mV
Common Mode Input Voltage Range	V <sub>I(R)</sub>		±12	±13		V
Common Mode Rejection Ratio	CMRR	R <sub>s</sub> <10kΩ	70	90		dB
Supply Voltage Rejection Ratio	PSRR	R <sub>s</sub> <10kΩ	76	90		dB
Output Voltage swing	V <sub>o</sub> (p-p)	R <sub>L</sub> >10kΩ		±12	±14	V
Power Consumption	P <sub>c</sub>			70	170	mV
Slew Rate	SR	V <sub>i</sub> =10V,R <sub>L</sub> >2kΩ,C <sub>L</sub> <100pF	1.2			V/μs
Rise Time	T <sub>RIS</sub>	V <sub>i</sub> =20mV,R <sub>L</sub> >2kΩ,C <sub>L</sub> <100pF		0.3		μs
Overshoot	OS	V <sub>i</sub> =20mV,R <sub>L</sub> >2kΩ,C <sub>L</sub> <100pF		15		%

**TYPICAL PERFORMANCE CHARACTERISTICS**

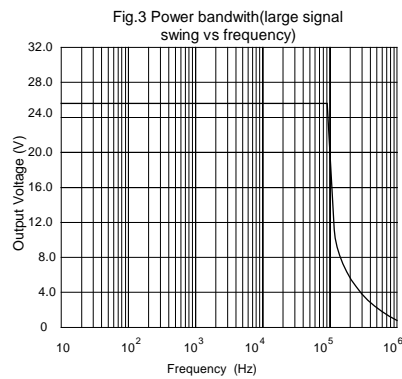
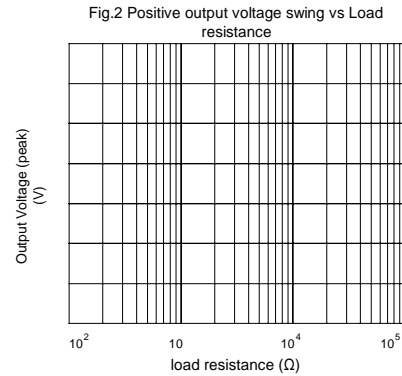
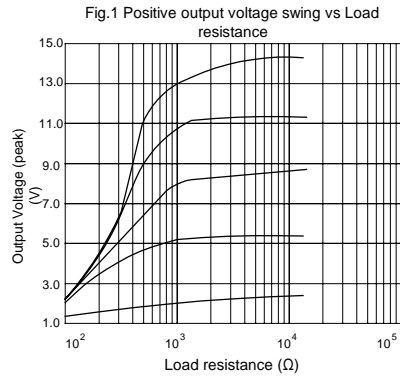

Fig. 4 Burst Noise vs Rs

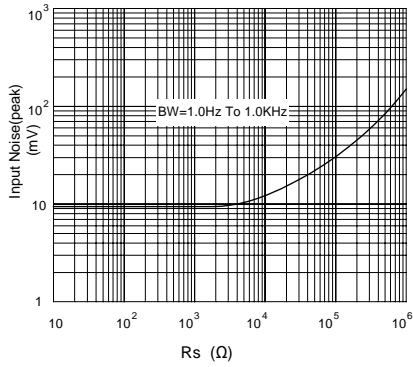

Fig. 5 RMS Noise vs Rs

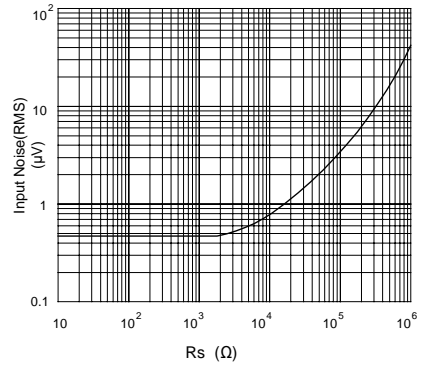

Fig. 6 Output Noise vs Rs

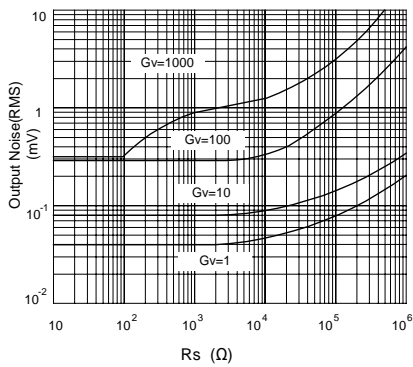

Fig. 7 Spectral Noise Density

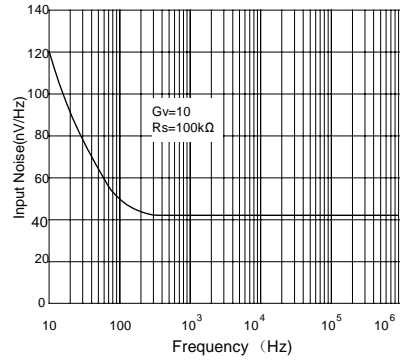

Fig. 8 Open loop frequency response

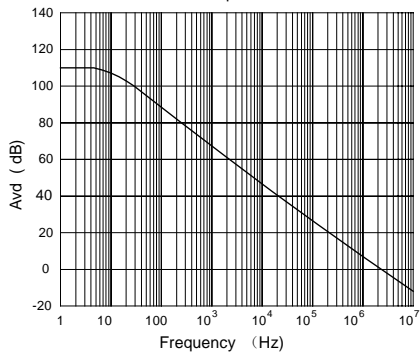
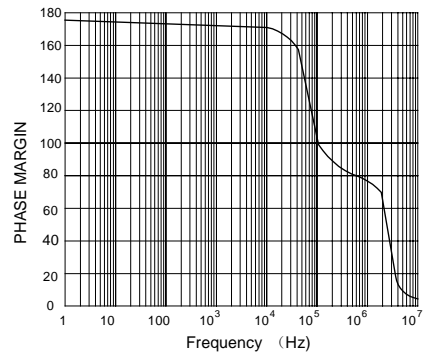

Fig. 9 PHASE MARGIN vs FREQUENCY



4558

PACKAGE DIMENSIONS

8-DIP-P-300

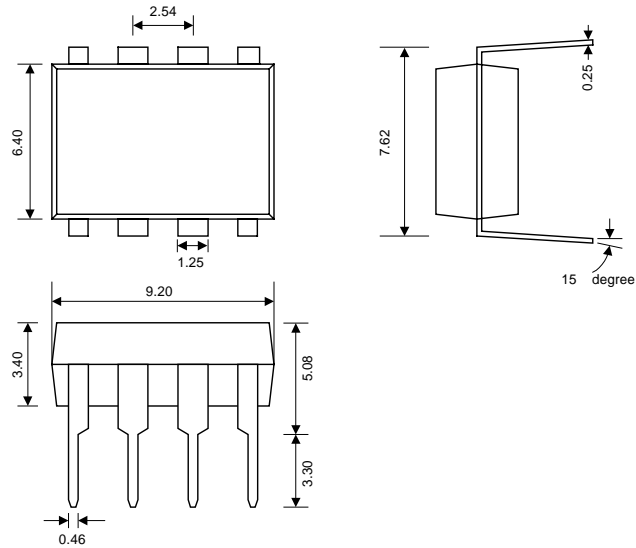

8-SOP-P

