

350mA High Speed Low Power LDO

Features

- Programmable output: Minimum can go to 0.8V
- Highly Accurate: $\pm 1.5\%$
- Dropout Voltage: 100mV @ 50mA (3.0V Typ.)
- High Ripple Rejection: 70dB @ 100Hz
- Internal protector: current limiter, short protector and over temperature protection
- Low Power Consumption: 50 μ A (Typ.)
- Minimum Output Current: 350mA ($V_{IN} \geq V_{OUT} + 1V$)
- Standby Current: less than 0.1 μ A
- Instructions with Power Good
- SOT23-5 and SOT23-6 packages

Applications

- Cellular Handsets
- Battery-Powered Equipment
- Wi-Fi Router
- Hand-Held Instruments
- Portable Information Application
- Adjustable power supply

General Description

The RP6212-ADJ series are highly precise, low noise, positive voltage LDO regulators manufactured using CMOS processes. The series achieves high ripple rejection and low dropout and consists of a standard voltage source, an error correction, current limiter and a phase compensation circuit plus a driver transistor. External output feedback, customers can easily get the required voltage. In order to make the load current does not exceed the current capacity of the output transistor, built-in over-current protection, over temperature protection and short circuit protection. RP6212-ADJ may have the POWER GOOD indicator. When the FB voltage reaches 0.75V, PG output is high. When the FB drops below 0.7V, PG output is low. The internal op amp with advanced structure, the output capacitor can be omitted.

Typical Application Circuit ⁽¹⁾⁽²⁾

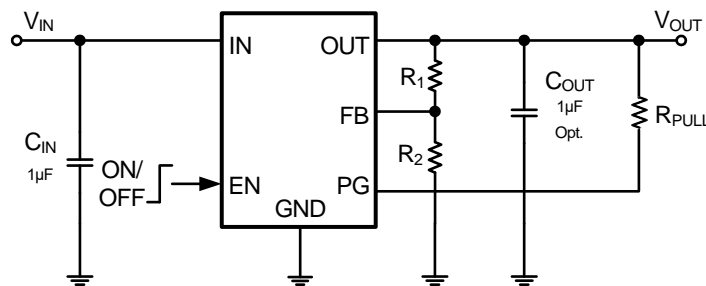

Figure1: Typical Application Circuit

Note1: $V_{OUT} = 0.8 \times (1 + R1/R2)$

Note2: $R2 \geq 100k\Omega$

350mA High Speed Low Power LDO

Pin Description

Pin Configuration

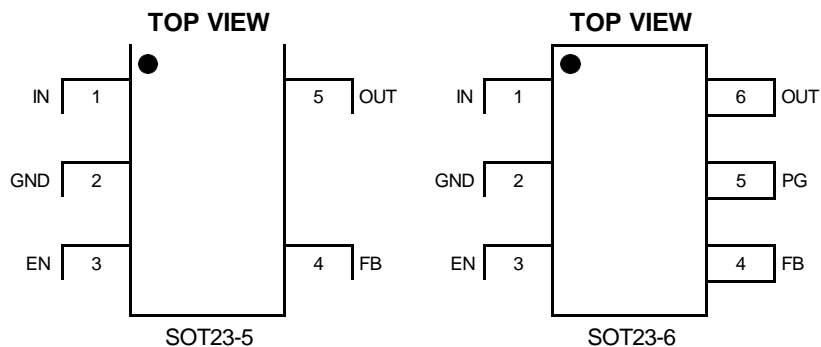

Pin Description

Pin No.		Pin Name	Function
SOT23-5	SOT23-6		
1	1	IN	Input voltage pin for the regulator
2	2	GND	Ground
3	3	EN	Enable Control
4	4	FB	FB pin for adjustable output option
/	5	PG	Power Good Pin
5	6	OUT	Output voltage pin for the regulator

Order Information ⁽¹⁾

RP6212-ADJ^{①②}

Designator	Symbol	Description		
ADJ	Integer	Output Voltage		
①	SOT5	SOT23-5		
	SOT6	SOT23-6		
②	*	ALL RoHS / Pb Free		
	*	ALL Halogen Free		
Part No.	Model	Description	Package	T/R Qty
70009	RP6212-ADJSOT5	RP6212-ADJSOT5 LDO, ADJ, SOT23-5	SOT23-5	3000PCS
70010	RP6212-ADJSOT6	RP6212-ADJSOT6 LDO, ADJ, SOT23-6	SOT23-6	3000PCS

Note (1): All RAINPRO parts are Pb-Free and adhere to the RoHS directive.

350mA High Speed Low Power LDO

Mark Rule

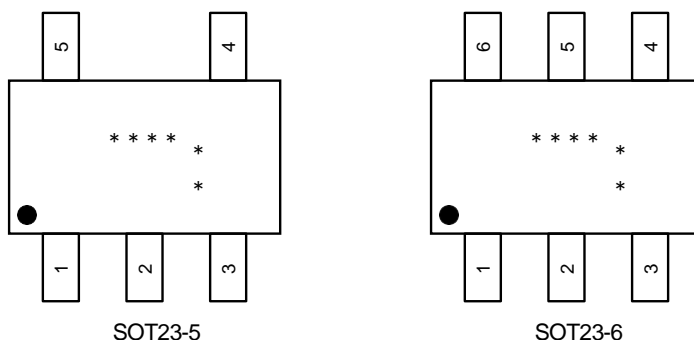

Represents product series

Parameter	Mark	Description
①	4	RP6212-ADJ

Represents active status

Parameter	Mark	Description
②	a	Active 'High' (pull-down resistor built in)
	b	Active 'High' (no pull-down resistor built in)
	c	Active 'Low' (pull-up resistor built in)
	d	Active 'Low' (no pull-up resistor built in)

Represents PG function

Parameter	Mark	Description
③	a	Without PG
	p	With PG

Represents customized code

Parameter	Mark	Description
④		Customized code

Represents production lot number

Parameter	Mark	Description
*		Lot No.

350mA High Speed Low Power LDO

Functional Block Diagram

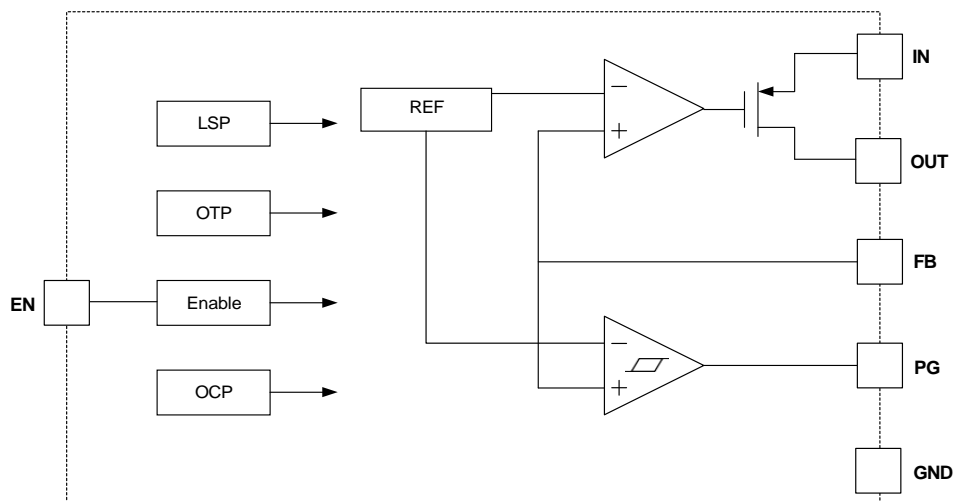

Functional Block Diagram

Specifications

Absolute Maximum Ratings ⁽¹⁾ ⁽²⁾

Item	Min	Max	Unit
V _{IN} voltage	2.0	8.0	V
V _{OUT} voltage	1.2	3.3	V
Output Current ⁽³⁾	350		mA
Power dissipation ⁽⁴⁾	Internally Limited		
Operating Ambient Temperature	-40	85	°C
Maximum junction temperature		150	°C
Storage temperature, T _{stg}	-50	85	°C
Lead Temperature (Soldering, 10sec.)		260	°C

Note (1): Exceeding these ratings may damage the device.

Note (2): The device is not guaranteed to function outside of its operating conditions.

Note (3): $I_{OUT} = P_D / (V_{IN} - V_{OUT})$

Note (4): The maximum allowable power dissipation is a function of the maximum junction temperature, T_{J(MAX)}, the junction-to-ambient thermal resistance, R_{θJA}, and the ambient temperature, T_A. The maximum allowable power dissipation at any ambient temperature is calculated using: $P_{D(MAX)} = (T_{J(MAX)} - T_A) / R_{\theta JA}$. Exceeding the maximum allowable power dissipation causes excessive die temperature, and the regulator goes into thermal shutdown. Internal thermal shutdown circuitry protects the device from permanent damage. Thermal shutdown engages at T_J=155 °C (typical) and disengages at T_J= 140 °C (typical).

350mA High Speed Low Power LDO

Recommended Operating Conditions

Item	Min	Max	Unit
Operating junction temperature ⁽¹⁾	-40	125	°C
Operating temperature range	-40	85	°C
Input voltage V_{IN}	2	6.5	V
Output current	0	300	mA

Note (1): All limits specified at room temperature ($T_A = 25\text{ °C}$) unless otherwise specified. All room temperature limits are 100% production tested. All limits at temperature extremes are ensured through correlation using standard Statistical Quality Control (SQC) methods. All limits are used to calculate Average Outgoing Quality Level (AOQL).

Thermal Information

Item	Description	SOT23 5 Pin	SOT23 6 Pin	Unit
$R_{\theta JA}$	Junction-to-ambient thermal resistance ⁽¹⁾⁽²⁾	230	105	°C/W
$R_{\theta JC(top)}$	Junction-to-case (top) thermal resistance	152	55	°C/W
$R_{\theta JB}$	Junction-to-board thermal resistance	56	17.5	°C/W
Ψ_{JT}	Junction-to-top characterization parameter	31	3.5	°C/W
Ψ_{JB}	Junction-to-board characterization parameter	55	17.5	°C/W
$R_{\theta JC(bot)}$	Junction-to-case (bottom) thermal resistance	N/A	N/A	°C/W

Note (1): The package thermal impedance is calculated in accordance to JESD 51-7.

Note (2): Thermal Resistances were simulated on a 4-layer, JEDEC board

350mA High Speed Low Power LDO

Electrical Characteristics

$T_A = 25\text{ }^\circ\text{C}$, unless otherwise noted.

Parameter	Symbol	Test Conditions	Min	Typ.	Max	Units	
Input Voltage	V_{IN}		2		6.5	V	
Feedback Voltage	V_{FB}	$V_{IN}=4.2\text{V}$, $V_{OUT}=3.3\text{V}$, $I_{OUT}=30\text{mA}$	790	800	810	mV	
Output Current	I_{OUT}	$V_{IN} \geq V_{OUT(S)} + 1.0\text{V}$		350		mA	
Dropout Voltage	V_{drop}	$I_{OUT}=50\text{ mA}$	-	0.10	0.15	V	
		$I_{OUT}=100\text{ mA}$	-	0.20	0.30		
Line Regulations	$\frac{\Delta V_{OUT}}{\Delta V_{IN} \times V_{OUT}}$	$V_{OUT(S)} + 0.5\text{ V} \leq V_{IN} \leq 7\text{V}$ $I_{OUT}=30\text{mA}$	-	0.20	0.30	%/V	
Load Regulation	ΔV_{OUT}	$V_{IN}=V_{OUT(S)}+1.0\text{ V}$ $1.0\text{mA} \leq I_{OUT} \leq 100\text{mA}$	-	50	100	mV	
Output Voltage Temperature Characteristics	$\frac{\Delta V_{OUT}}{T_A \times V_{OUT}}$	$V_{IN}=V_{OUT(S)}+1.0\text{V}$, $I_{OUT}=10\text{mA}$ $-40^\circ\text{C} \leq T_A \leq 85^\circ\text{C}$	-	± 100	-	ppm/ $^\circ\text{C}$	
Supply Current	I_{SS1}	$V_{IN}=V_{OUT(S)}+1.0\text{ V}$	-	50	70	μA	
Shutdown Current	I_{shut}	$V_{IN}=5\text{V}$, $V_{EN}=0$			0.1	μA	
Power Supply Rejection Ratio	PSRR	$V_{OUT}=1.2\text{V}$, $V_{IN}=2\text{V}$	$f = 100\text{Hz}$	-	70	-	dB
			$f = 1\text{kHz}$		65	-	dB
Output Voltage Noise (BW=10Hz to 100kHz, $C_{OUT}=10\mu\text{F}$)		$V_{IN} = 3.5\text{V}$ $I_{LOAD} = 0.1\text{A}$	$V_{OUT}=0.9\text{V}$		30		μV_{RMS}
			$V_{OUT}=2.8\text{V}$		40		
Short-circuit Current	I_{short}	$V_{IN}=V_{OUT(S)}+1.0\text{V}$, ON/OFF Terminal is ON, $V_{OUT}=0\text{V}$	-	100	-	mA	
EN "High Voltage"	V_{ENH}		0.9			V	
EN "Low" Voltage	V_{ENL}				0.4	V	
EN "High Current"	I_{ENH}	$V_{IN}=V_{EN}=V_{OUT(T)}+1\text{V}$	-0.1		0.1	μA	
EN "Low" Current	I_{ENL}	$V_{IN}=V_{OUT(T)}+1\text{V}$, $V_{EN}=V_{SS}$	-0.1		0.1	μA	
Thermal Shutdown Temperature	T_{SD}	$I_{LOAD} = 10\text{mA}$		155		$^\circ\text{C}$	
Thermal Shutdown Hysteresis	ΔT_{SD}			15		$^\circ\text{C}$	

350mA High Speed Low Power LDO

Typical Performance Characteristics ⁽⁸⁾

Note (8): Typical performance characteristics below based on Output Voltage=3.3V

1、 The input voltage transient response

Test Conditions: Vin=4.3V-5.3V, Iout=10mA, Cin=Cout=1uF

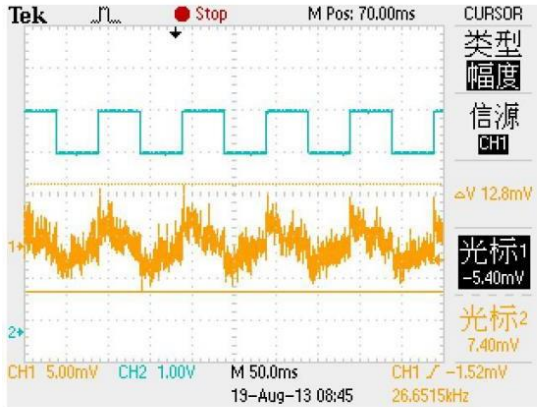

Channel 2 input, channel 1 Output

2、 Ripple rejection

Test Conditions: Vin=4.3V-5.3V, Iout=10mA, Cin=Cout=1uF

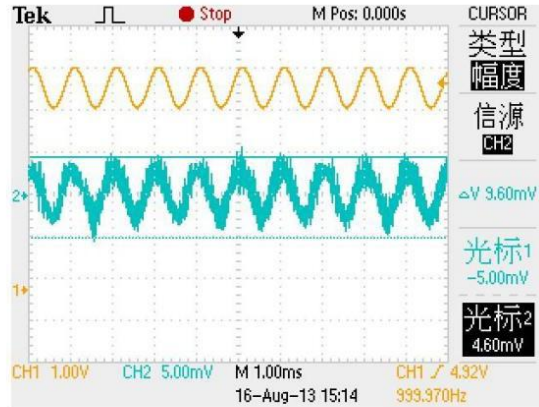

Channel 1 input, channel 2 Output

3、 The load transient response

Test Conditions: Vin=CE=4.3V, Cin=Cout=1uF, Iout=0-100mA

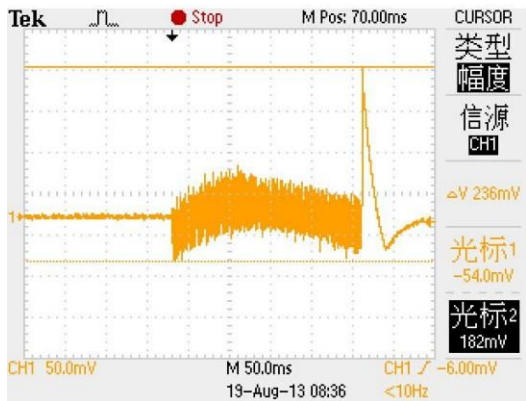

5、 Overshoot

Test Conditions: Vin=0V-4.3V, Iout=0mA, Cin=Cout=1uF

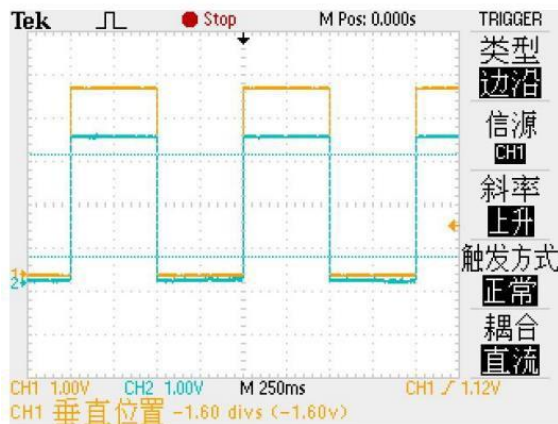

Channel 1 input, channel 2 Output

4、 The output voltage temperature curve

Test Conditions: Vin=CE=4.3V, Cin=Cout=1uF, Iout=10mA

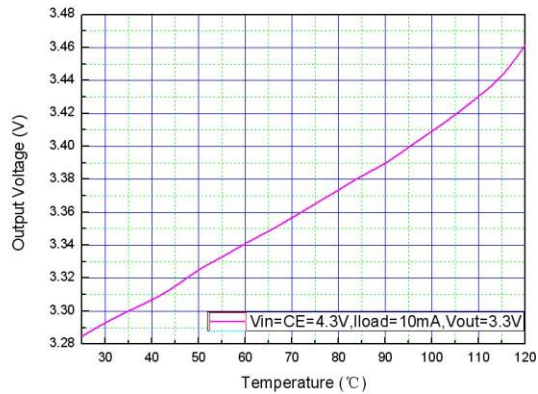

350mA High Speed Low Power LDO

Applications Information

Setting the Output Voltage

RP6212-ADJ require an input capacitor and an output capacitor. These components are critical to the performance of the device. The output voltage can be programmed by resistor divider.

$$V_{OUT} = V_{FB} \times \frac{R1 + R2}{R2}$$

V _{OUT} (V)	R1(KΩ)	R2(KΩ)	C _{IN} (μF)	C _{OUT} (μF)
1	25.00	100	1~10	1~10
1.05	31.25	100	1~10	1~10
1.2	50.00	100	1~10	1~10
1.5	87.50	100	1~10	1~10
1.8	125.00	100	1~10	1~10
2.5	212.50	100	1~10	1~10
2.8	250.00	100	1~10	1~10
3.3	312.50	100	1~10	1~10
3.6	350.00	100	1~10	1~10

Low ESR Capacitors

With the RP6212-ADJ series, a stable output voltage is achievable even if used with low ESR capacitors as a phase compensation circuit is built-in. In order to ensure the effectiveness of the phase compensation, we suggest that an output capacitor (C_{OUT}) is connected as close as possible to the output pin (V_{OUT}) and the GND pin. Please use an output capacitor with a capacitance value of 10uF. Also, please connect an input capacitor (C_{IN}) of 10uF between the V_{IN} pin and the GND pin in order to ensure a stable power input. Stable phase compensation may not be ensured if the capacitor runs out capacitance when depending on bias and temperature. In case the capacitor depends on the bias and temperature, please make sure the capacitor can ensure the actual capacitance.

Current Limiter, Short-Circuit Protection

The RP6212-ADJ series includes a combination of a fixed current limiter circuit & a feedback circuit, which aid the operations of the current limiter and circuit protection. When the load current reaches the current limit level, the fixed current limiter circuit operates and output voltage drops. As a result of this drop-in output voltage, the feedback circuit operates, output voltage drops further and output current decreases. When the output pin is shorted, a current of about 50mA flows.

EN pin

The IC's internal circuitry can be shutdown via the signal from the EN pin with the RP6212-ADJ series. Driving EN over 0.9 V turns on the regulator. Driving EN below 0.4 V puts the regulator into shutdown mode. The operational logic of the IC's EN pin is selectable. Note that as the standard RP6212-ADJ type's regulator is 'High Active/No Pull-Down', operations will become unstable with the EN pin open. Although the EN pin is equal to an inverter input with CMOS hysteresis, with either the pull-up or pull-down options, the EN pin input current will

350mA High Speed Low Power LDO

increase when the IC is in operation. We suggest that you use this IC with either a V_{IN} voltage or a GND voltage input at the EN pin. If this IC is used with the correct specifications for the EN pin, the operational logic is fixed and the IC will operate normally. However, supply current may increase as a result of through current in the IC's internal circuitry.

Notes on Use

1. Please use this IC within the stated absolute maximum ratings. The IC is liable to malfunction should the ratings be exceeded.
2. Where wiring impedance is high, operations may become unstable due to noise and/or phase lag depending on output current. Please keep the resistance low between V_{IN} and GND wiring in particular.
3. Please wire the input capacitor (C_{IN}) and the output capacitor (C_{OUT}) as close to the IC as possible.

350mA High Speed Low Power LDO

Packaging Information

5-Pin SOT23 Packaging Information

SOT23-5

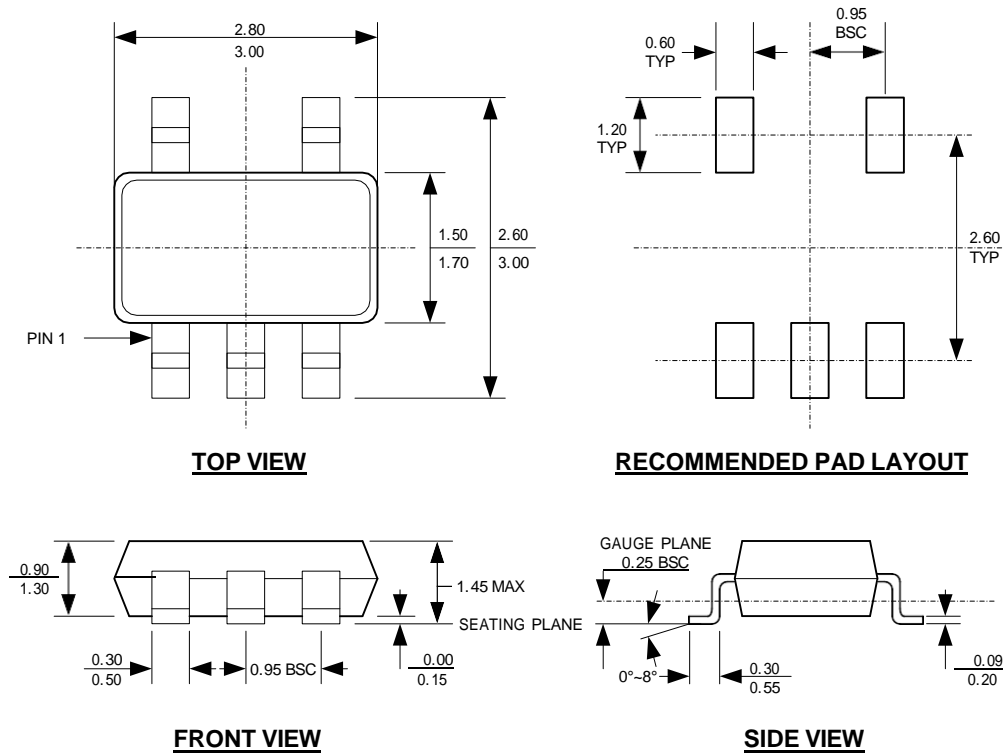

NOTE:

1. CONTROL DIMENSION IS IN INCHES. DIMENSION IN BRACKET IS IN MILLIMETERS.
2. PACKAGE LENGTH DOES NOT INCLUDE MOLD FLASH, PROTRUSIONS OR GATE BURRS.
3. PACKAGE WIDTH DOES NOT INCLUDE INTERLEAD FLASH OR PROTRUSIONS.
4. LEAD COPLANARITY (BOTTOM OF LEADS AFTER FORMING) SHALL BE 0.004" INCHES MAX.
5. DRAWING CONFORMS TO JEDEC MS-012, VARIATION BA.
6. DRAWING IS NOT TO SCALE.

350mA High Speed Low Power LDO

5-Pin SOT23 Packaging Information

SOT23-6

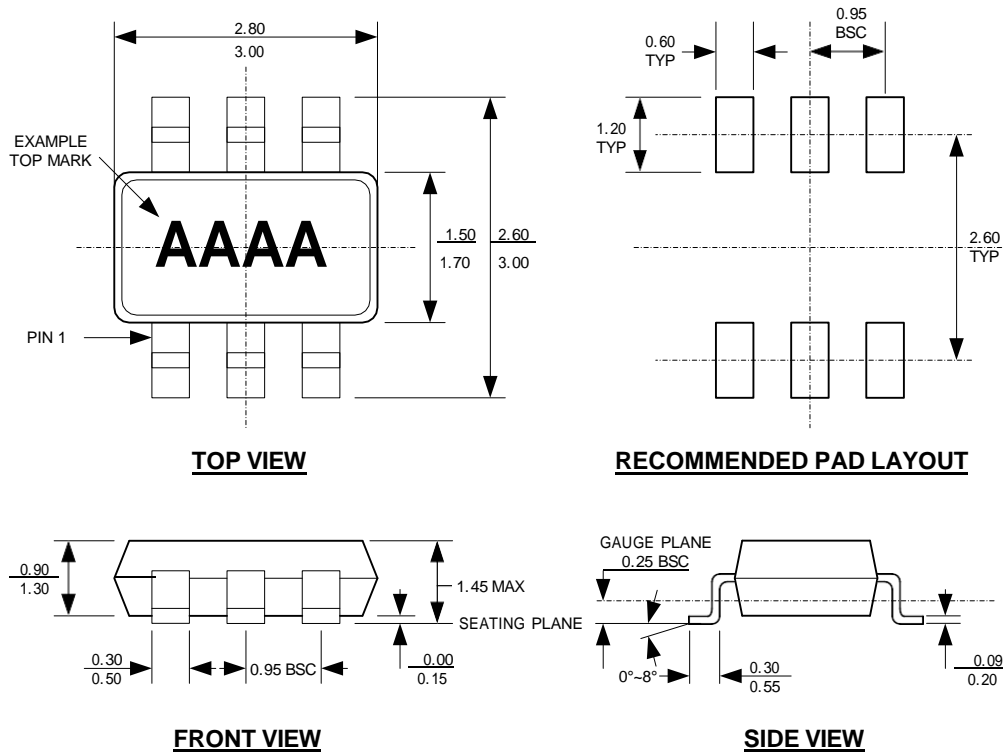

NOTE:

1. CONTROL DIMENSION IS IN INCHES. DIMENSION IN BRACKET IS IN MILLIMETERS.
2. PACKAGE LENGTH DOES NOT INCLUDE MOLD FLASH, PROTRUSIONS OR GATE BURRS.
3. PACKAGE WIDTH DOES NOT INCLUDE INTERLEAD FLASH OR PROTRUSIONS.
4. LEAD COPLANARITY (BOTTOM OF LEADS AFTER FORMING) SHALL BE 0.004" INCHES MAX.
5. DRAWING CONFORMS TO JEDEC MS-012, VARIATION BA.
6. DRAWING IS NOT TO SCALE.

Copyright ©2019-2024, ShenZhen ShengDeXin Technology CO.,LTD.
ShenZhen ShengDeXin Technology CO.,LTD. reserves the right to make, from time to time, such departures from the detail specifications as may be required to permit improvements in the performance, reliability, or manufacturability of its products. Before placing an order, the user is cautioned to verify that the information being relied upon is current.
ShengDeXin's products are not to be used in life support devices or systems, if a failure of an ShengDeXin product can reasonably be expected to cause the failure of that life support device or system, or to affect the safety or effectiveness of that device or system.
The information included herein is believed to be accurate and reliable. However, ShenZhen ShengDeXin Technology CO.,LTD. assumes no responsibility for its use; nor for any infringement of patents or other rights of third parties which may result from its use.

For the latest version of this document, visit our website:
<http://www.o2orgin.com>

Attention

- products fail with some probability. It is possible that these probabilistic failures could give rise to accidents or events that could endanger human lives, that could give rise to smoke or fire, or that could cause damage to other property. When designing equipment, adopt safety measures so that these kinds of accidents or events cannot occur. Such measures include but are not limited to protective circuits and error prevention circuits for safe design, redundant design, and structural design.
- Specifications of any and all ShenZhen ShengDeXin Technology CO.,LTD.S products described or contained herein stipulate the performance, characteristics, and functions of the described products in the independent state, and are not guarantees of the performance, characteristics, and functions of the described products as mounted in the customer's products or equipment. To verify symptoms and states that cannot be evaluated in an independent device, the customer should always evaluate and test devices mounted in the customer's products or equipment.
- Any and all ShenZhen ShengDeXin Technology CO.,LTD.products described or contained herein do not have specifications that can handle applications that require extremely high levels of reliability, such as life-support systems, aircraft's control systems, Military applications, aerospace, space, scientific research and exploration, or other applications whose failure can be reasonably expected to result in serious physical and/or material damage. Consult with your ShenZhen ShengDeXin Technology CO.,LTD. representative nearest you before using any ShenZhen ShengDeXin Technology CO.,LTD. products described or contained herein in such applications, But we welcome discussions with our Alpha team to develop advanced product application scenarios.
- ShenZhen ShengDeXin Technology CO.,LTD. assumes no responsibility for equipment failures that result from using products at values that exceed, even momentarily, rated values (such as maximum ratings, operating condition ranges, or other parameters) listed in products specifications of any and all ShenZhen ShengDeXin Technology CO.,LTD. products described or contained herein.
- In the event that any or all ShenZhen ShengDeXin Technology CO.,LTD. products(including technical data, services) described or contained herein are controlled under any of applicable local export control laws and regulations, such products must not be exported without obtaining the export license from the authorities concerned in accordance with the above law.
- No part of this publication may be reproduced or transmitted in any form or by any means, electronic or mechanical, including photocopying and recording, or any information storage or retrieval system, or otherwise, without the prior written permission of ShenZhen ShengDeXin Technology CO.,LTD..
- Information (including circuit diagrams and circuit parameters) herein is for example only ; it is not guaranteed for volume production. ShenZhen ShengDeXin Technology CO.,LTD believes information herein is accurate and reliable, but no guarantees are made or implied regarding its use or any infringements of intellectual property rights or other rights of third parties.
 - Any and all information described or contained herein are subject to change without notice due to product/technology improvement, etc. When designing equipment, refer to the "Delivery Specification" for the ShenZhen ShengDeXin Technology CO.,LTD. product that you intend to use.