

2.5V-5.5V_{IN}, 40V_{OUT}, 1.2MHz Boost Regulator

Features

- 2.5V to 5.5V Input Voltage
- Up to 40V Output Voltage
- 1.2MHz Fixed Switching Frequency
- 0.1/0.2/0.25/0.3/0.6V Feedback Voltage
- Internal 1.6A Switch Current Limit
- Support Analog and PWM Dimming Mode
- Internal 40V Over Voltage Protection
- Internal Compensation
- Thermal Shutdown
- Driving Up to 10 White LEDs
- Dimming with wide Frequency Range
- Available in SOT23-5, DFN2×2-6 package

Applications

- Camera Flash White LED
- Digital still cameras
- PDA LED back light
- LCD Bias Supply

General Description

The RP3740 series is a step-up converter designed for driving up to 10 white LEDs or up to 40V output voltage from a single cell Lithium Ion battery. The device features integrated overvoltage protection and feedback voltage is regulated to 100mV to 600mV. Low feedback voltage helps to reduce power loss and improve efficiency. Customers can choose different FB voltages according to their application. Optimized operation frequency can meet the requirement of small LC filters value and low operation current with high efficiency. Internal soft start function can reduce the inrush current. Both SOT23-5 and DFN2×2-6 package type provides the best solution for PCB space saving and total BOM cost.

Typical Application Circuit

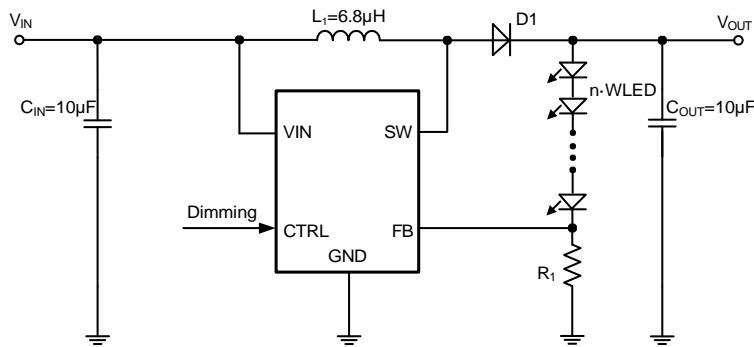

Typical White LED Application Circuit

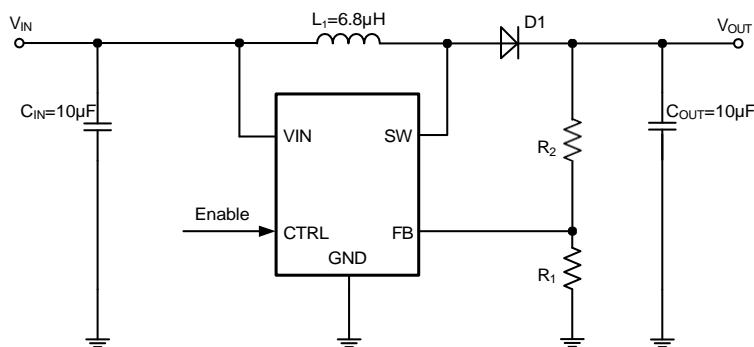

Typical Boost Application Circuit

2.5V-5.5V_{IN}, 40V_{OUT}, 1.2MHz Boost Regulator

Package and Pin Description

Pin Configuration

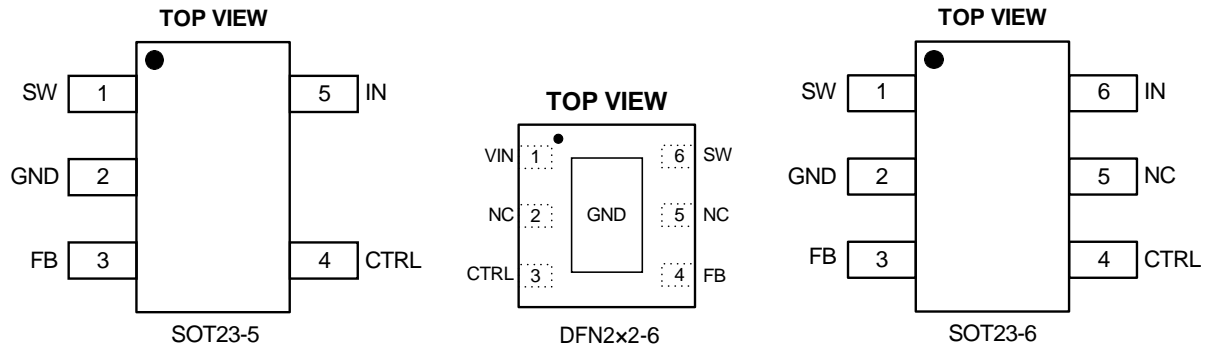

Pin Description

SOT23-5 Pin No.	DFN2x2-6 Pin No.	SOT23-6 Pin No.	Name	Function
1	6	1	SW	Power Switch Output. SW is the drain of the internal MOSFET switch. Connect the power inductor and output rectifier to SW. SW can swing between GND and 40V.
2	EPAD	2	GND	Ground Pin.
3	4	3	FB	Feedback Reference Voltage Pin. Series connect a resistor between WLED and ground as a current sense. Sense the current feedback voltage to set the current rating.
4	3	4	CTRL	CTRL pin of the boost converter. It is a multi-functional pin which can be used for enable control and PWM dimming. Should not be left floating.
5	1	6	IN	Input Supply Pin. Must be locally bypassed.
NA	2, 3	5	NC	No Connection.

Order Information ⁽¹⁾

Marking ⁽²⁾	Part No.	Model	Description	Package	T/R Qty
Ka <u>YLL</u>	700100	RP3740ASOT5	RP3740ASOT5 Boost, VIN 2.5-5.5V, VOUT VIN-40V, 1.2MHz, VFB0.1V, SOT23-5	SOT23-5	3000PCS
Kb <u>YLL</u>	790101	RP3740BSOT5	RP3740BSOT5 Boost, VIN 2.5-5.5V, VOUT VIN-40V, 1.2MHz, VFB0.2V, SOT23-5	SOT23-5	3000PCS
Kc <u>YLL</u>	703102	RP3740CSOT5	RP3740CSOT5 Boost, VIN 2.5-5.5V, VOUT VIN-40V, 1.2MHz, VFB0.25V, SOT23-5	SOT23-5	3000PCS
Kc <u>YLL</u>	703005	RP3740CSOT6	RP3740CSOT6 Boost, VIN 2.5-5.5V, VOUT VIN-40V, 1.2MHz, VFB0.25V, SOT23-6	SOT23-6	3000PCS
Kr <u>YLL</u>	703113	RP3740CDFN6	RP3740CDFN6 Boost, VIN 2.5-5.5V, VOUT VIN-40V, 1.2MHz, VFB0.25V, DFN2x2-6	DFN2x2-6	3000PCS

KdYLL	700103	RP3740DSOT5	RP3740DSOT5 Boost, VIN 2.5-5.5V, VOUT VIN-40V, 1.2MHz, VFB0.3V, SOT23-5	SOT23-5	3000PCS
KeYLL	700104	RP3740ESOT5	RP3740ESOT5 Boost, VIN 2.5-5.5V, VOUT VIN-40V, 1.2MHz, VFB0.6V, SOT23-5	SOT23-5	3000PCS
KqYLL	700112	RP3740EDFN6	RP3740EDFN6 Boost, VIN 2.5-5.5V, VOUT VIN-40V, 1.2MHz, VFB0.6V, DFN2×2-6	DFN2×2-6	3000PCS

Note (1): All RAINPRO parts are Pb-Free and adhere to the RoHS directive.

Note (2): Top Marking: KxYLL [device code: Kx (x=a, b, c, d, e, r, q), Y=year code, LL= lot number code)

Specifications

Absolute Maximum Ratings ^{(1) (2)}

Item	Min	Max	Unit
V _{IN} , V _{CTRL} voltage	-0.3	6	V
V _{SW} , V _{OVP} voltage	-0.3	42	V
V _{SW} , V _{OVP} voltage (10ns transient)	-5	43	V
All Other Pins	-0.3	6	V
Power dissipation ⁽³⁾	Internally Limited		
Operating junction temperature, T _J	-40	150	°C
Storage temperature, T _{stg}	-65	150	°C
Lead Temperature (Soldering, 10sec.)		260	°C

Note (1): Exceeding these ratings may damage the device.

Note (2): The device is not guaranteed to function outside of its operating conditions.

Note (3): The maximum allowable power dissipation is a function of the maximum junction temperature, T_{J(MAX)}, the junction-to-ambient thermal resistance, R_{θJA}, and the ambient temperature, T_A. The maximum allowable power dissipation at any ambient temperature is calculated using: P_{D(MAX)} = (T_{J(MAX)} - T_A)/R_{θJA}. Exceeding the maximum allowable power dissipation causes excessive die temperature, and the regulator goes into thermal shutdown. Internal thermal shutdown circuitry protects the device from permanent damage. Thermal shutdown engages at T_J=160 °C (typical) and disengages at T_J= 130 °C (typical).

ESD Ratings

Item	Description	Value	Unit
V _(ESD-HBM)	Human Body Model (HBM) ANSI/ESDA/JEDEC JS-001-2014 Classification, Class: 2	±2000	V
V _(ESD-CDM)	Charged Device Mode (CDM) ANSI/ESDA/JEDEC JS-002-2014 Classification, Class: C0b	±200	V
I _{LATCH-UP}	JEDEC STANDARD NO.78E APRIL 2016 Temperature Classification, Class: I	±150	mA

2.5V-5.5V_{IN}, 40V_{OUT}, 1.2MHz Boost Regulator

Recommended Operating Conditions

Item	Min	Max	Unit
Operating junction temperature ⁽¹⁾	-40	125	°C
Operating temperature range	-40	85	°C
Input voltage V _{IN}	2.5	5.5	V
Output voltage V _{OUT}	V _{IN}	38	V

Note (1): All limits specified at room temperature (T_A = 25 °C) unless otherwise specified. All room temperature limits are 100% production tested. All limits at temperature extremes are ensured through correlation using standard Statistical Quality Control (SQC) methods. All limits are used to calculate Average Outgoing Quality Level (AOQL).

Thermal Information

Item	Description	SOT23-5	DFN2×2-6	Unit
R _{θJA}	Junction-to-ambient thermal resistance ⁽¹⁾⁽²⁾	180	67.8	°C/W
R _{θJC(top)}	Junction-to-case (top) thermal resistance	130	88.5	°C/W
R _{θJB}	Junction-to-board thermal resistance	45	37.2	°C/W
ψ _{JT}	Junction-to-top characterization parameter	35	2.0	°C/W
ψ _{JB}	Junction-to-board characterization parameter	45	37.6	°C/W
R _{θJC}	Junction-to-case (Bottom) thermal resistance	NA	7.9	°C/W

Note (1): The package thermal impedance is calculated in accordance to JESD 51-7.

Note (2): Thermal Resistances were simulated on a 4-layer, JEDEC board

Electrical Characteristics ^{(1) (2)}

V_{IN}=5V, T_A=25 °C, unless otherwise specified.

Parameter	Test Conditions	Min	Typ.	Max	Unit
Input voltage range		2.5		5.5	V
Output voltage range				38	V
Supply Current (Quiescent)	V _{FB} = 110%		200	250	μA
Supply Current (Shutdown)	V _{CTRL} = 0 or C _{TRL} = GND		0.1	1	μA
Feedback Voltage		(1-2.5%) Typ.	Typ.	(1+2.5%) Typ.	mV
SW On Resistance			400	650	mΩ
Internal SW Current Limit			1.6		A
OVP Protection Threshold			40		V
Switching Frequency			1.2		MHz
Maximum Duty Cycle	V _{FB} =90%		85		%
Minimum On-Time			80		ns
EN Rising Threshold		1.1			V
EN Falling Threshold				0.6	V
Under-Voltage Lockout Threshold	Wake up V _{IN} Voltage		2.3	2.5	V
	Shutdown V _{IN} Voltage	1.7	1.9		V
	Hysteresis V _{IN} voltage		400		mV
Soft Start			600		μS
Thermal Shutdown			160		°C

2.5V-5.5V_{IN}, 40V_{OUT}, 1.2MHz Boost Regulator

Thermal Hysteresis			30		°C
--------------------	--	--	----	--	----

Note (1): MOSFET on-resistance specifications are guaranteed by correlation to wafer level measurements.

Note (2): Thermal shutdown specifications are guaranteed by correlation to the design and characteristics analysis.

2.5V-5.5V_{IN}, 40V_{OUT}, 1.2MHz Boost Regulator

Typical Performance Characteristics ^{(1) (2)}

Note (1): Performance waveforms are tested on the evaluation board.

Note (2): V_{IN}=5V, V_{OUT}=18V, 5 LEDs, T_A = +25 °C, unless otherwise noted.

Efficiency vs. LED Current

V_{OUT}=9V, 3 LEDs

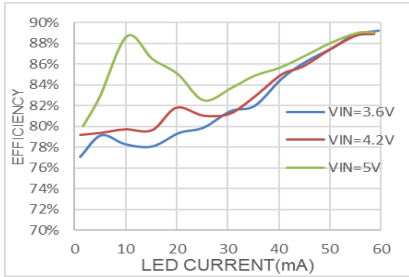

Efficiency vs. LED Current

V_{OUT}=18V, 5 LEDs

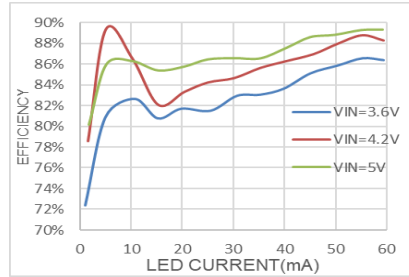

Efficiency vs. LED Current

V_{OUT}=36V, 10 LEDs

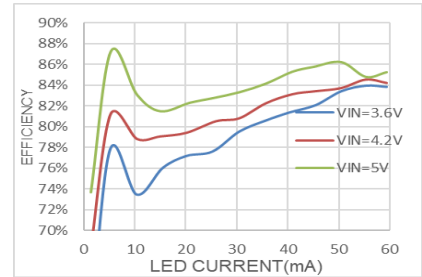

Efficiency vs. Input Voltage

Typical I_{LED}=11.5mA

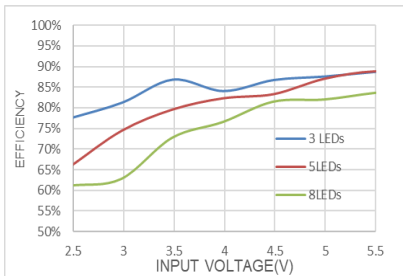

LED Current Regulation vs. Input Voltage

Typical I_{LED}=11.5mA

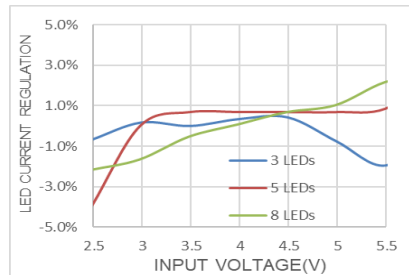

LED Current vs. PWM Duty Cycle

V_{IN}=5V, V_{OUT}=18V, 5 LEDs

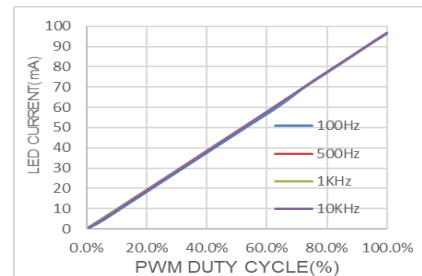

Steady State Operation

V_{IN}=5V, V_{OUT}=18V, 5 LEDs, I_{LED}=60mA

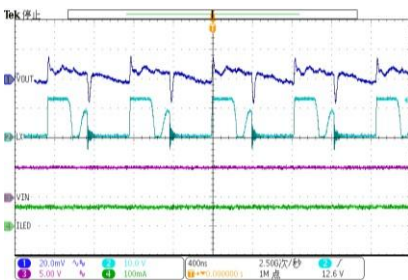

V_{IN} Startup

V_{IN}=5V, V_{OUT}=18V, 5 LEDs, I_{LED}=60mA

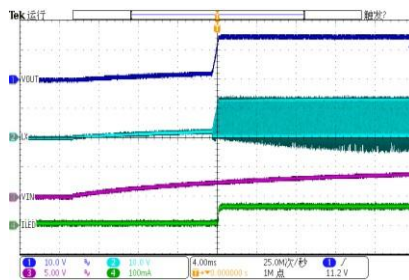

Enable Startup

V_{IN}=5V, V_{OUT}=18V, 5 LEDs, I_{LED}=60mA

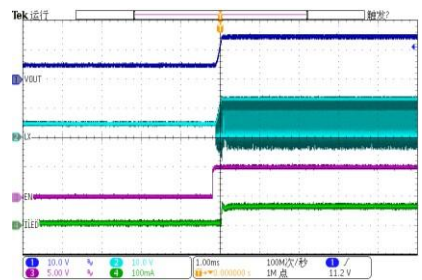

2.5V-5.5V_{IN}, 40V_{OUT}, 1.2MHz Boost Regulator

Dimming Operation

V_{IN}=5V, V_{OUT}=18V, 5LEDs, f=100Hz

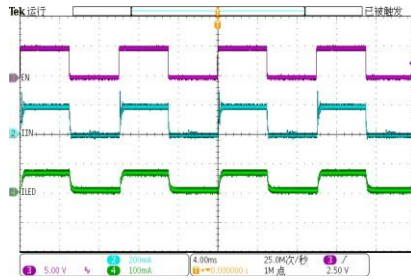

Dimming Operation

V_{IN}=5V, V_{OUT}=18V, 5LEDs, f=1KHz

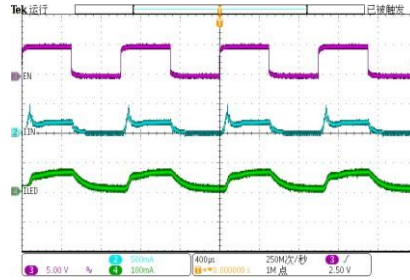

Dimming Operation

V_{IN}=5V, V_{OUT}=18V, 5LEDs, f=10KHz

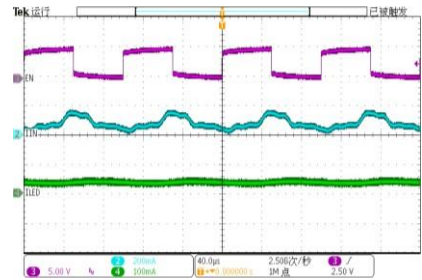

Open Load Protection

V_{IN}=5V, V_{OUT} Open

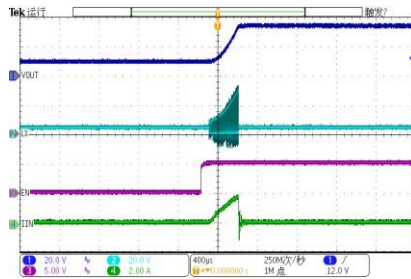

Open Load Protection

V_{IN}=5V, V_{OUT} Open

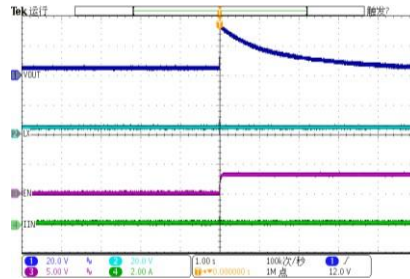

2.5V-5.5V_{IN}, 40V_{OUT}, 1.2MHz Boost Regulator

Functional Block Diagram

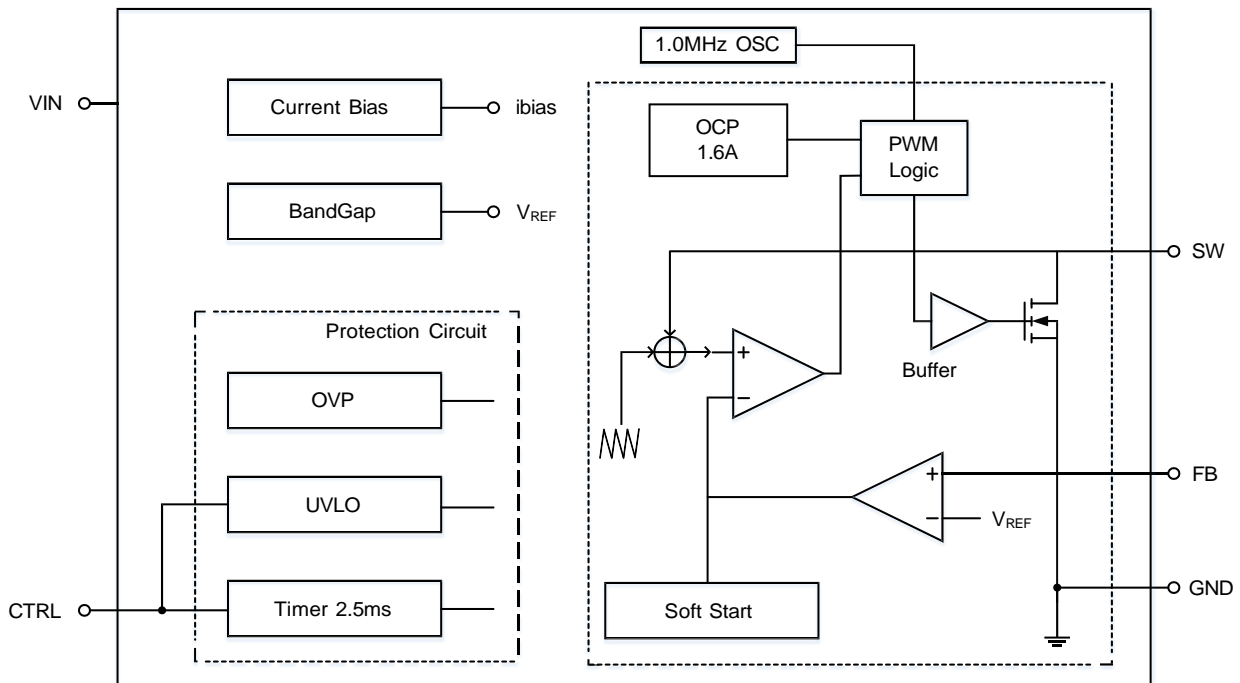

Block Diagram

Functions Description

Under-Voltage Lockout (UVLO)

Under-voltage lockout (UVLO) protects the chip from operating at an insufficient supply voltage. UVLO protection monitors the internal regulator voltage. When the voltage is lower than UVLO threshold voltage, the device is shut off. When the voltage is higher than UVLO threshold voltage, the device is enabled again.

Enable and PWM Dimming

When the input voltage is above maximal UVLO rising threshold and the CTRL pin is pulled high, the RP3740 series is enabled. When the CTRL pin is pulled low, the RP3740 series goes into shutdown mode. In shutdown mode, less than 1 μ A input current is consumed. Because there is a conductive path from the input to the output through the inductor and Schottky diode, the output voltage is equal to the input voltage during shutdown. The CTRL pin allows disabling and enabling of the device as well as brightness control of the LEDs by applying a PWM signal up to typically 1kHz. When a PWM signal is applied, the LED current is turned on when the CTRL is high and off when CTRL is pulled low. Changing the PWM duty cycle therefore changes the LED brightness.

Soft-Start

The RP3740 series begins soft start when the CTRL pin is pulled high. At the beginning of the soft start period, the isolation FET is turned on slowly to charge the output capacitor. After the pre-charge phase, the RP3740 series starts switching. This is called switching soft start phase. An internal soft start circuit limits the peak inductor current according to the output voltage. The switching soft start phase is about 600 μ s typically. The soft start function

2.5V-5.5V_{IN}, 40V_{OUT}, 1.2MHz Boost Regulator

reduces the inrush current during startup.

Over-Voltage Protection

As with any current source, the output voltage rises when the output gets high impedance or disconnected. To prevent the output voltage exceeding the maximum switch voltage rating of the main switch, an over voltage protection circuit is integrated. As soon as the output voltage exceeds the OVP threshold, the converter stops switching and the output voltage falls.

Efficiency and Feedback Voltage

The feedback voltage has a direct effect on the converter efficiency. Because the voltage drop across the feedback resistor does not contribute to the output power (LED brightness), the lower the feedback voltage, the higher the efficiency. Especially when powering only three or less LEDs, the feedback voltage impacts the efficiency around 2% depending on the sum of the forward voltage of the LEDs.

Thermal Shutdown

Thermal shutdown prevents the chip from operating at exceedingly high temperatures. When the silicon die temperature exceeds 160 °C, it shuts down the whole chip. When the temperature falls below its lower threshold (Typ. 130 °C) the chip is enabled again.

LED Applications Information ⁽¹⁾

Note (1): The following dimming methods are based on the RP3740CSOT5 250mV FB voltage value. Different FB need to choose different resistors and external DC voltage signals to get the desired ILED value.

Setting the LED Current

The LED current is controlled by the feedback resistor, R_1 . The current through the LEDs is given by the equation V_{FB}/R_1 . I_{LED} is average LED current. According to the Superposition Theorem, we can implement the analog dimming function, and we provide a variety of different FB voltage to choose from, which can help customers more easily adapt to their application needs.

Dimming Control

1. Using a PWM Signal to CTRL Pin

For controlling the LED brightness, the RP3740 series can perform the dimming control by applying a PWM signal to CTRL pin. The internal soft start and the wide range dimming frequency can eliminate inrush current and audio noise when dimming. The average LED current is proportional to the PWM signal duty cycle. The magnitude of the PWM signal should be higher than the minimum enables voltage of CTRL pin, in order to let the dimming control perform correctly for preventing the flicker issue, the selected PWM frequency is $\geq 100\text{Hz}$ and $\leq 10\text{KHz}$.

2. Using a DC Voltage

When CTRL remains high level, using a variable DC voltage to adjust the brightness is a popular method in some applications. According to the Superposition Theorem, as the DC voltage increases, the voltage contributed to VFB increases and the voltage drop on R_2 decreases, i.e. the LED current decreases. For example, the 250mV FB voltage RP3740CSOT5 can use a DC voltage ranging from 0V-2.8V to adjust the LED current, the selection of resistors sets dimming control of LED current from 20mA to 0mA.

2.5V-5.5V_{IN}, 40V_{OUT}, 1.2MHz Boost Regulator

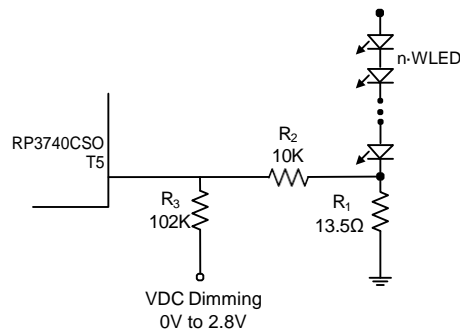

The LED current can be calculated by the following Equation:

$$I_{LED} = \frac{V_{FB} - \frac{R_2 \times (V_{DC} - V_{FB})}{R_3}}{R_1}$$

3. Using a Filtered PWM signal

Another common application is using a filtered PWM signal as an adjustable DC voltage for LED dimming control. A filtered PWM signal acts as the DC voltage to regulate the output current. In this circuit, the output ripple depends on the frequency of PWM signal. For smaller output voltage ripple (<100mV), the recommended frequency of 2.8V PWM signal should be above 2kHz. To fix the frequency of PWM signal and change the duty cycle of PWM signal can get different output current.

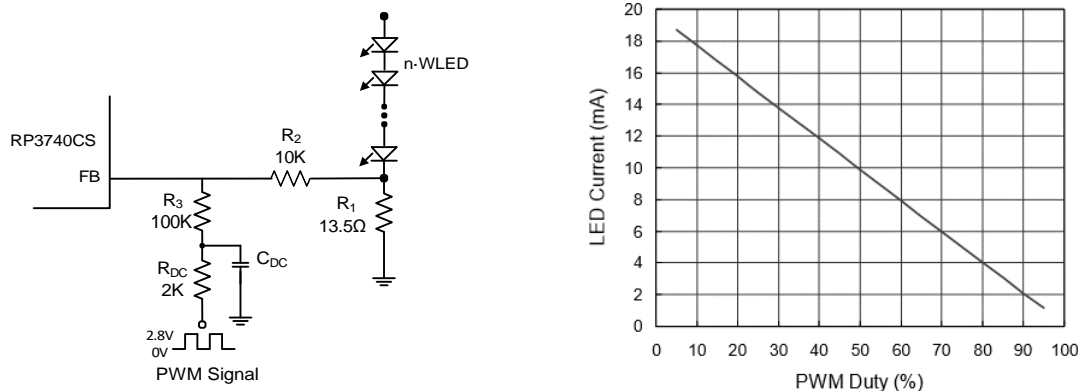

The LED current can be calculated by the following Equation:

$$I_{LED} = \frac{V_{FB} - \frac{R_2 \times (V_{PWM} \times Duty - V_{FB})}{R_3 + R_{DC}}}{R_1}$$

Inductor Selection

The recommended value of inductor for most applications are 4.7 to 22μH. Small size and better efficiency are the major concerns for portable device, such as RP3740 series used for mobile phone. When selecting the inductor, the inductor saturation current should be rated as high as the peak inductor current at maximum load, and respectively, maximum LED current.

Output Capacitor Selection

The device is designed to operate with a wide selection of ceramic output capacitors. The selection of the output capacitor value is a trade-off between output voltage ripple and capacitor cost and form factor. In general, capacitor

2.5V-5.5V_{IN}, 40V_{OUT}, 1.2MHz Boost Regulator

values of 10 μF can be used. For better voltage filtering, ceramic capacitors with low ESR are recommended. X5R and X7R types are suitable because of their wider voltage and temperature ranges.

Input Capacitor Selection

For good input voltage filtering, low ESR ceramic capacitors are recommended. A 10 μF ceramic input capacitor is sufficient for most of the applications. For better input voltage filtering and EMI reduction, this value can be increased. The input capacitor should be placed as close as possible to the input pin of the converter.

Diode Selection

A Schottky diode should be used for the output diode. The forward current rating of the diode should be higher than the load current, and the reverse voltage rating must be higher than the output voltage. Do not use ordinary rectifier diodes, since slow switching speeds and long recovery times cause the efficiency and the load regulation to suffer.

Boost Applications Information

Typical Application

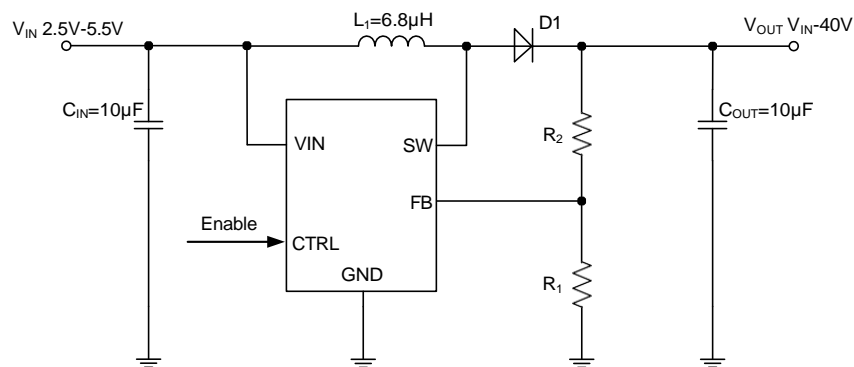

Setting the Output Voltage

The RP3740 Series can also be used for boost converter dedicated for small to medium LCD bias supply. Set different voltage divider resistors to get the desired output according to FB. The output voltage can be programmed by resistor divider, as shown in Equation:

$$V_{OUT} = V_{FB} \times \left(1 + \frac{R2}{R1}\right)$$

The RP3740 Series operates with an input voltage range of 2.5V to 5.5V and can generate output voltages up to 40 V. The device operates in a pulse-frequency-modulation (PFM) scheme with constant peak current control. This control scheme maintains high efficiency over the entire load current range, and with a switching frequency up to 1 MHz, the device enables the use of very small external components.

2.5V-5.5V_{IN}, 40V_{OUT}, 1.2MHz Boost Regulator

Layout Guidelines

PC board layout is an important part of DC-DC converter design. Poor board layout can disrupt the performance of a DC-DC converter and surrounding circuitry by contributing to EMI, ground bounce, and resistive voltage loss in the traces. These can send erroneous signals to the DC-DC converter resulting in poor regulation or instability. Good layout can be implemented by following a few simple design rules.

1. Minimize area of switched current loops. Input capacitor should be placed as close as possible to the VIN terminal. Grounding for both the input and output capacitors should consist of a small localized topside plane that connects to GND. The inductor should be placed as close as possible to the SW pin and output capacitor.
2. Minimize the copper area of the switch node. The SW terminals should be directly connected with a trace that runs on top side directly to the inductor. To minimize IR losses this trace should be as short as possible and with an enough width. However, a trace that is wider than 100 mils will increase the copper area and cause too much capacitive loading on the SW terminal. The inductors should be placed as close as possible to the SW terminals to further minimize the copper area of the switch node.
3. Have a single point ground for all device analog grounds. The ground connections for the feedback components should be connected then routed to the GND pin of the device. This prevents any switched or load currents from flowing in the analog ground plane. If not properly handled, poor grounding can result in degraded load regulation or erratic switching behavior.
4. Minimize trace length to the FB terminal. The feedback trace should be routed away from the SW pin and inductor to avoid contaminating the feedback signal with switch noise.
5. Make input and output bus connections as wide as possible. This reduces any voltage drops on the input or output of the converter and can improve efficiency. If voltage accuracy at the load is important make sure feedback voltage sense is made at the load. Doing so will correct for voltage drops at the load and provide the best output accuracy.

2.5V-5.5V_{IN}, 40V_{OUT}, 1.2MHz Boost Regulator

Package Description

SOT23-5

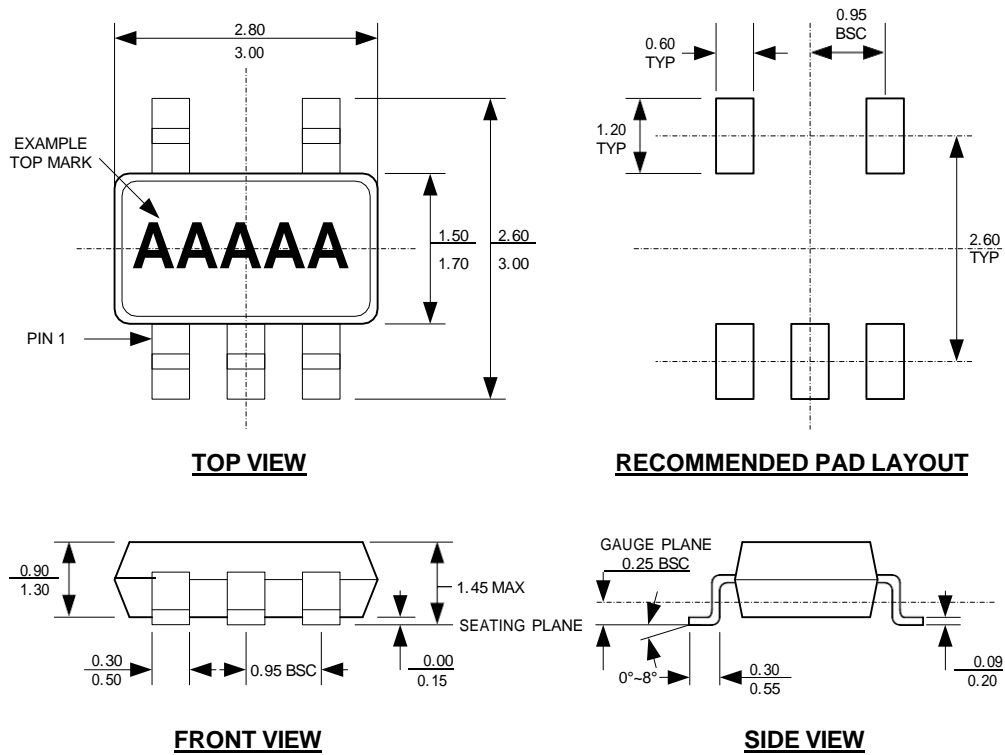

NOTE:

- CONTROL DIMENSION IS IN INCHES. DIMENSION IN BRACKET IS IN MILLIMETERS.
- PACKAGE LENGTH DOES NOT INCLUDE MOLD FLASH, PROTRUSIONS OR GATE BURRS.
- PACKAGE WIDTH DOES NOT INCLUDE INTERLEAD FLASH OR PROTRUSIONS.
- LEAD COPLANARITY (BOTTOM OF LEADS AFTER FORMING) SHALL BE 0.004" INCHES MAX.
- DRAWING CONFORMS TO JEDEC MS-012, VARIATION BA.
- DRAWING IS NOT TO SCALE.

2.5V-5.5V_{IN}, 40V_{OUT}, 1.2MHz Boost Regulator

DFN2x2-6 Package Description

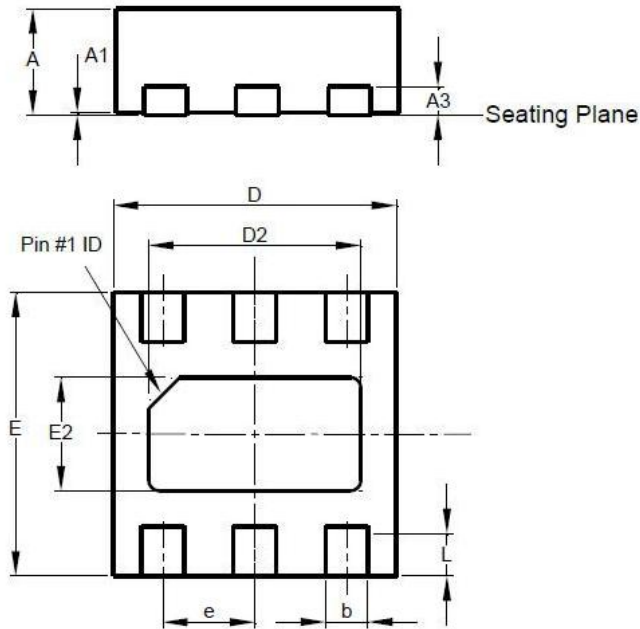

Dim	Min	Max	Typ
A	0.70	0.80	0.75
A1	0.00	0.05	--
A3	0.20 REF		
b	0.25	0.35	0.30
D	1.95	2.075	2.00
D2	1.35	1.60	1.50
E	1.95	2.075	2.00
E2	0.65	0.90	0.80
e	0.65 BSC		
L	0.25	0.45	0.35
All Dimensions in mm			

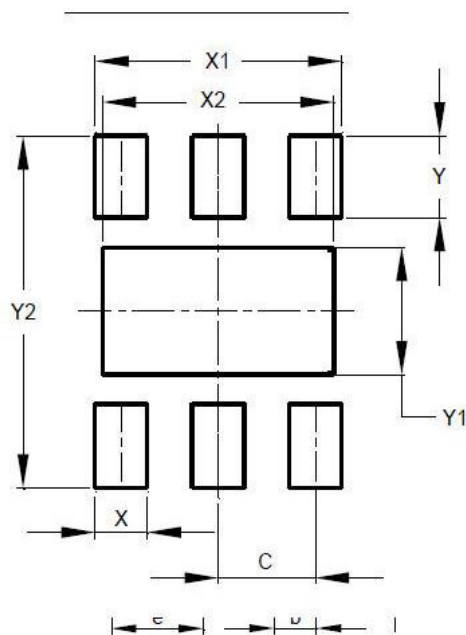

Dimensions	Value (in mm)
C	0.650
X	0.350
X1	1.650
X2	1.550
Y	0.545
Y1	0.850
Y2	2.350

Copyright ©2019-2024, ShenZhen ShengDeXin Technology CO.,LTD.

ShenZhen ShengDeXin Technology CO.,LTD. reserves the right to make, from time to time, such departures from the detail specifications as may be required to permit improvements in the performance, reliability, or manufacturability of its products. Before placing an order, the user is cautioned to verify that the information being relied upon is current.

ShengDeXin's products are not to be used in life support devices or systems, if a failure of an ShengDeXin product can reasonably be expected to cause the failure of that life support device or system, or to affect the safety or effectiveness of that device or system.

The information included herein is believed to be accurate and reliable. However, ShenZhen ShengDeXin Technology CO.,LTD. assumes no responsibility for its use; nor for any infringement of patents or other rights of third parties which may result from its use.

For the latest version of this document, visit our website:
<http://www.o2orgin.com>

Attention

- products fail with some probability. It is possible that these probabilistic failures could give rise to accidents or events that could endanger human lives, that could give rise to smoke or fire, or that could cause damage to other property. When designing equipment, adopt safety measures so that these kinds of accidents or events cannot occur. Such measures include but are not limited to protective circuits and error prevention circuits for safe design, redundant design, and structural design.
- Specifications of any and all ShenZhen ShengDeXin Technology CO.,LTD.S products described or contained herein stipulate the performance, characteristics, and functions of the described products in the independent state, and are not guarantees of the performance, characteristics, and functions of the described products as mounted in the customer's products or equipment. To verify symptoms and states that cannot be evaluated in an independent device, the customer should always evaluate and test devices mounted in the customer's products or equipment.
- Any and all ShenZhen ShengDeXin Technology CO.,LTD.products described or contained herein do not have specifications that can handle applications that require extremely high levels of reliability, such as life-support systems, aircraft's control systems, Military applications, aerospace, space, scientific research and exploration, or other applications whose failure can be reasonably expected to result in serious physical and/or material damage. Consult with your ShenZhen ShengDeXin Technology CO.,LTD. representative nearest you before using any ShenZhen ShengDeXin Technology CO.,LTD. products described or contained herein in such applications , But we welcome discussions with our Alpha team to develop advanced product application scenarios.
- ShenZhen ShengDeXin Technology CO.,LTD. assumes no responsibility for equipment failures that result from using products at values that exceed, even momentarily, rated values (such as maximum ratings, operating condition ranges, or other parameters) listed in products specifications of any and all ShenZhen ShengDeXin Technology CO.,LTD. products described or contained herein.
- In the event that any or all ShenZhen ShengDeXin Technology CO.,LTD. products(including technical data, services) described or contained herein are controlled under any of applicable local export control laws and regulations, such products must not be exported without obtaining the export license from the authorities concerned in accordance with the above law.
- No part of this publication may be reproduced or transmitted in any form or by any means, electronic or mechanical, including photocopying and recording, or any information storage or retrieval system, or otherwise, without the prior written permission of ShenZhen ShengDeXin Technology CO.,LTD..
- Information (including circuit diagrams and circuit parameters) herein is for example only ; it is not guaranteed for volume production. ShenZhen ShengDeXin Technology CO.,LTD believes information herein is accurate and reliable, but no guarantees are made or implied regarding its use or any infringements of intellectual property rights or other rights of third parties.
- Any and all information described or contained herein are subject to change without notice due to product/technology improvement, etc. When designing equipment, refer to the "Delivery Specification" for the ShenZhen ShengDeXin Technology CO.,LTD. product that you intend to use.